



Allerly House

Allerly Lodge

Standalane

Crimond

Friars Hall

Well

Friarshaugh View

EX ACCESS WHICH MEETS SBC ROADS AUTHORITIES STANDARDS

PASSING PLACE

GARDEN

PROPOSED MATURE HEDGE

EX HEDGE

Greywalls

Path

Drain

SEE MCKAY & PARTNERS DWG 21/011/01 NEW ACCESS ROAD LAYOUT

OLD BADGER SETT

NOTE: FINISHED FLOOR LEVEL IS 750MM ABOVE 200 YEAR FLOOD PLAIN

- PROPOSED SITE OUTLINED RED
- PROPOSED NEW ACCESS ROAD
- EXISTING TARMAC FIELD ACCESS ROAD

AH Aidan Hume Design Ltd
Architectural Services
113 Channel Street
Galashiels
TD1 1BN
email: - aidan.ahdesign@outlook.com
tel: - 07792 597343 or 07788 420822

Project:
PROPOSED DEVELOPMENT SITE FOR A SINGLE DWELLING HOUSE FRIARSHAUGH FARM GATTONSIDE TD6 9LT

Client:
MR & MRS N. CAMERON

Title:
SITE LOCATION PLAN (indicative)

Scale: N/A	Paper size: A3	Drawn by: 355100	Date: 15.09.21
Project no:	Drawing no:	Issue:	

AH129 P01 B2

© Aidan Hume Design Ltd. This drawing should not be copied or reproduced, or used for other than the noted project, without prior consent.

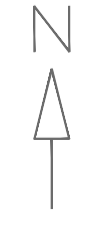

354700

354800

354900

355000

355100

700

800

900

1000

1100

109.7m

+ 100.0m

R10.00m

R15.00m

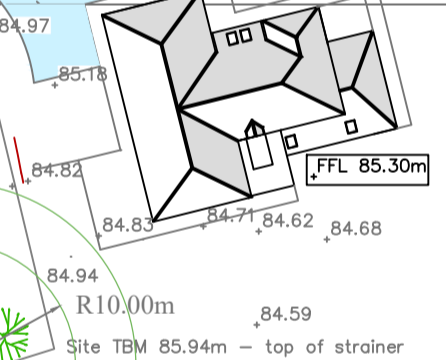

Tank (cov)